

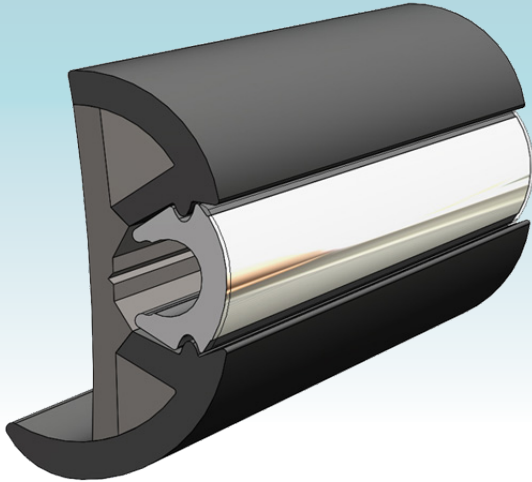

2" X 1.156" MEDIUM SUPROFLEX RUB RAIL



Add the ultimate coverage to the cap/hull joint of your boat with the V11-9950 SuproFlex Rub Rail. This co-extruded, ultra-flexible vinyl profile features a longer leg for superior hull protection. Available now to boat builders! SuproFlex Rub Rail is lightweight and super flexible to save you time and money while providing a seamless precision fit. The innovative SuproFlex series is co-extruded vinyl that provides two levels of hardness - ensuring enhanced protection from impact. SuproFlex Rub Rail requires minimal heating - reducing installation time and manpower. Additionally, SuproFlex Rub Rail requires no pre-forming and easily molds to most hull shapes. This new rub rail is available in a variety of sizes and colors, and pairs with TACO's Flex Chrome Insert, which can also be customized to any builder's color preference.

FEATURES & BENEFITS

- ▶ Patent USD950772S1
- ▶ Ideal for boats up to 65'
- ▶ Co-extruded to provide two levels of hardness
- ▶ Rigid backing and soft durometer front
- ▶ Shock-absorbing channels for higher impact resistance
- ▶ V11-9950 installs with the leg on top
- ▶ Lighter weight than traditional vinyl rub rail
- ▶ Requires no pre-forming and minimal heating
- ▶ Pairs with inserts V12-0307CP, V12-0307BP, V12-0307WP (sold separately)
- ▶ Insert color can be customized to builder's

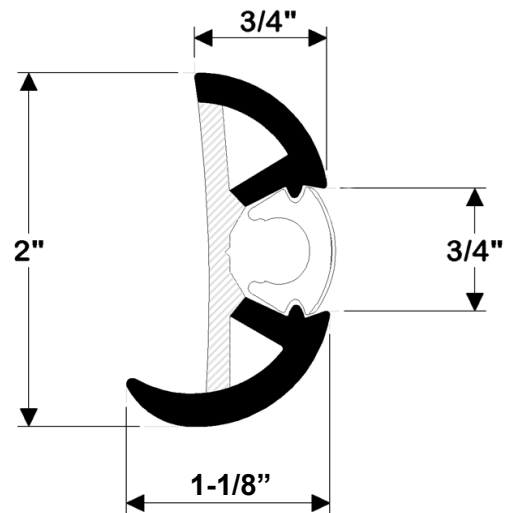

PART #	DESCRIPTION	COLOR	LENGTH
V11-9950BKA88D	SuproFlex, medium, 2" X 1.156"	Black	88'
V11-9950GRD88D	SuproFlex, medium, 2" X 1.156"	Gray	88'
V11-9950WHA88D	SuproFlex, medium, 2" X 1.156"	Arctic White	88'
V11-9950WHC88D	SuproFlex, medium, 2" X 1.156"	Frosty White	88'